

P11=P14=P15=P18=P24=P32=P33=P34=P36=P38
 =P40=P43=P44=P45=P46=P54=P56=P57=P59
 =P65

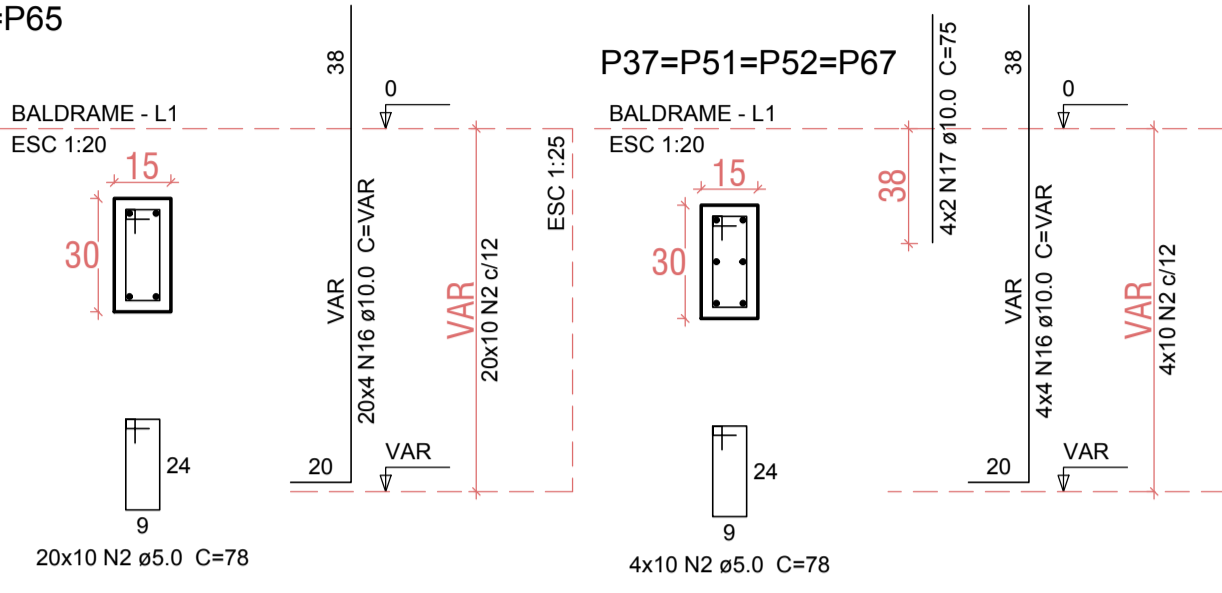

S11=S14=S15=S18=S24=S32=S33=S34=S36=S37
 =S38=S40=S43=S44=S45=S46=S51=S52=S54
 =S56=S57=S59=S65=S67

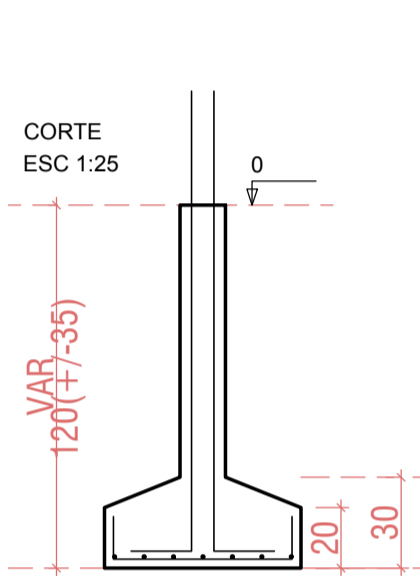
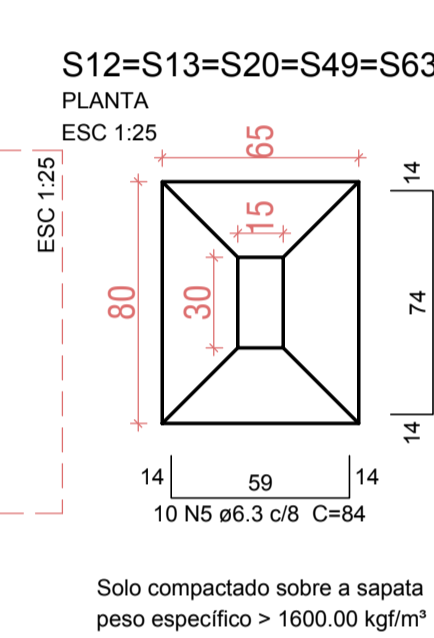
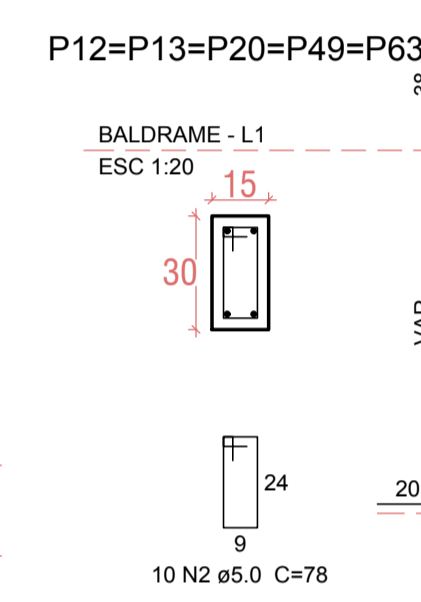
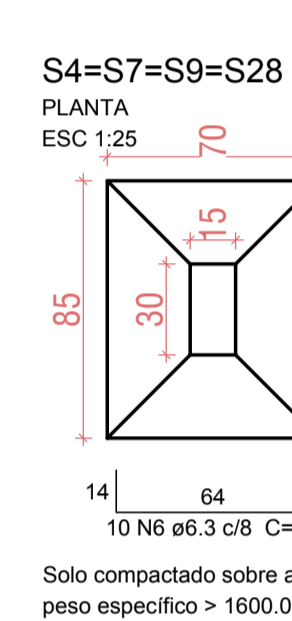
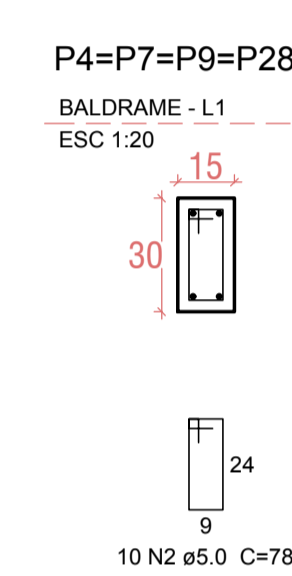
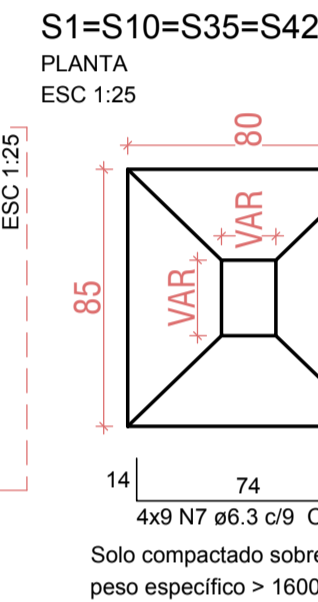
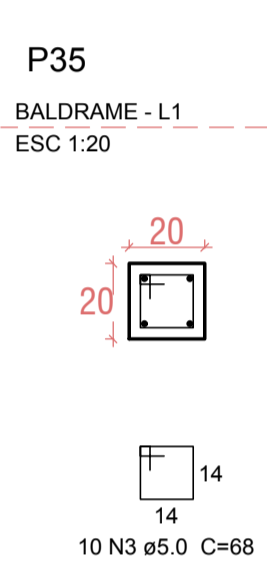
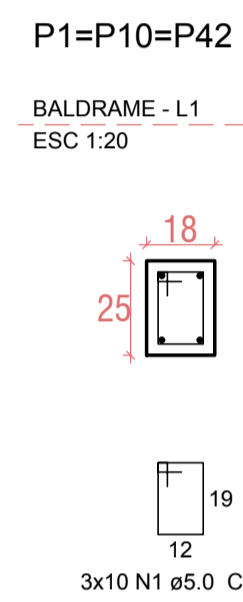
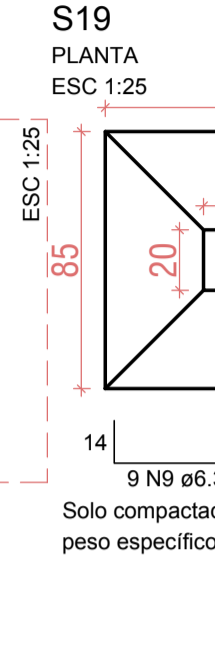
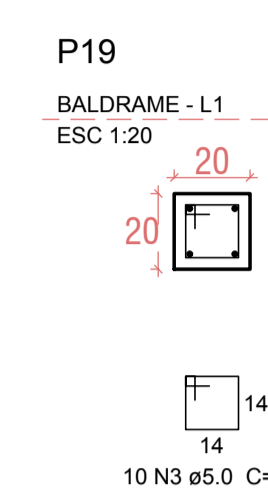
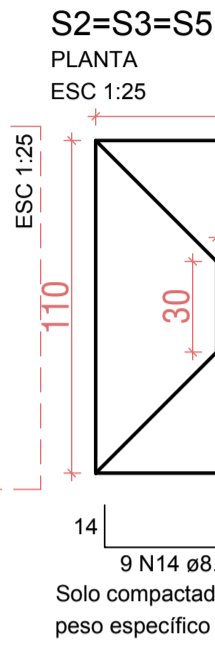
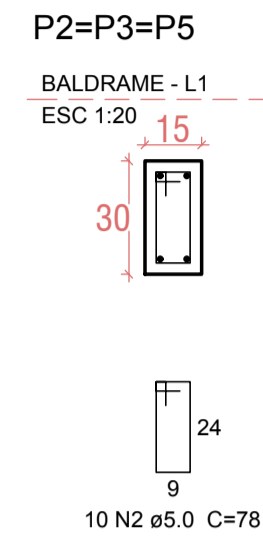
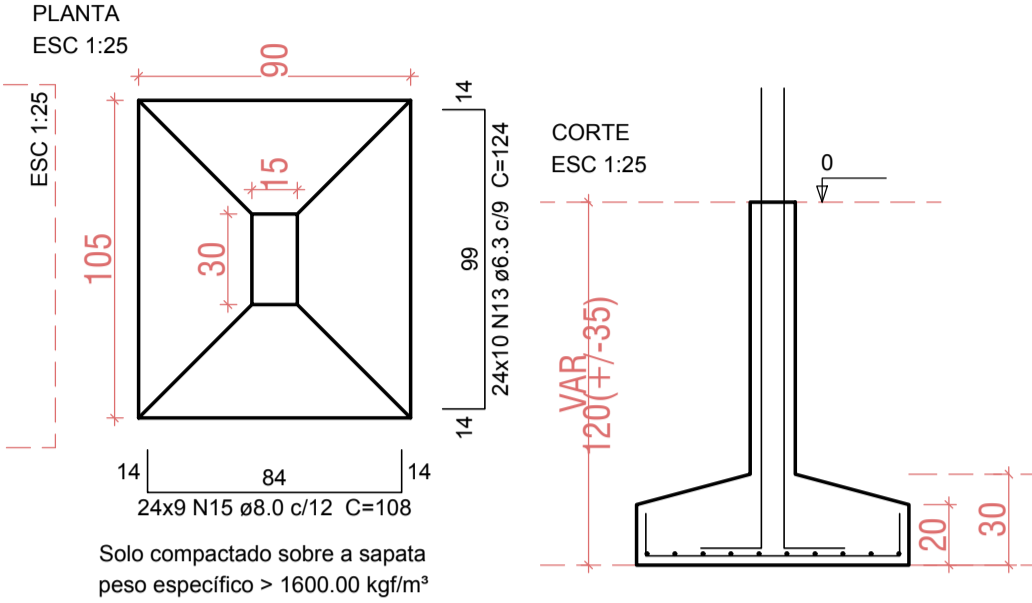

Relação do aço

AÇO	N	DIAM (mm)	QUANT (Barras)	UNIT (cm)	C.TOTAL (cm)
CA60	1	5.0	70	74	5180
	2	5.0	560	78	43680
	3	5.0	40	68	2720
	4	5.0	10	84	840
CA50	5	6.3	86	84	7224
	6	6.3	64	89	5696
	7	6.3	311	99	30789
	8	6.3	27	94	2538
	9	6.3	82	104	8528
	10	6.3	162	114	18468
	11	6.3	42	109	4578
	12	6.3	36	129	4644
	13	6.3	240	124	29760
	14	8.0	27	113	3051
	15	8.0	216	108	23328
	16	10.0	272	VAR	VAR
	17	10.0	10	75	750

P16=P17=P21=P22=P23=P25=P26=P29=P30=P39
 =P47=P48=P50=P55=P58=P61=P66

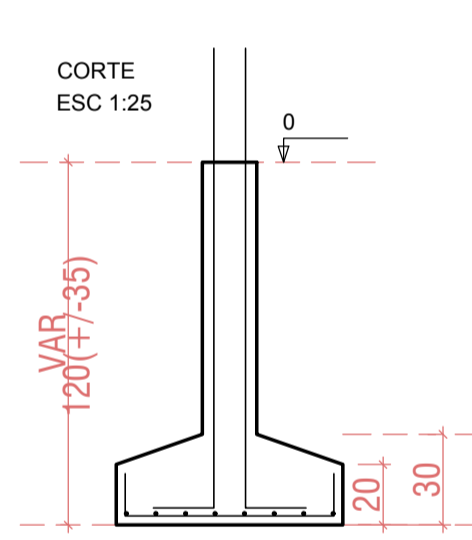
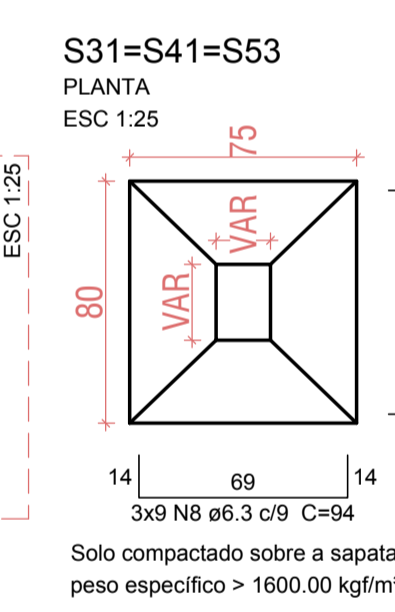
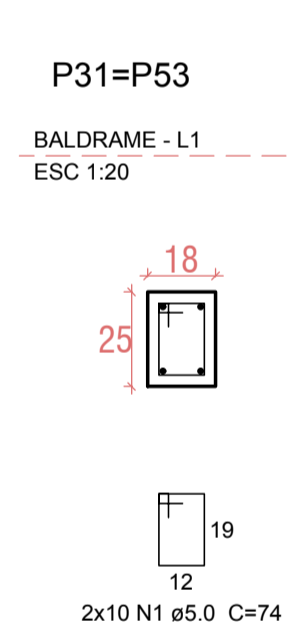
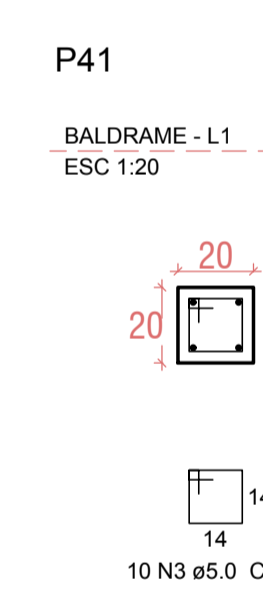
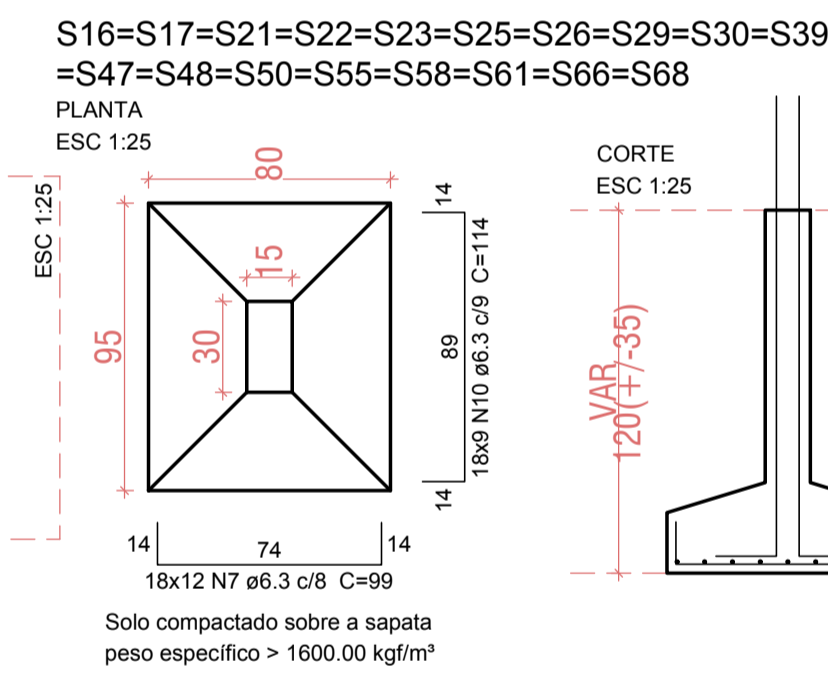
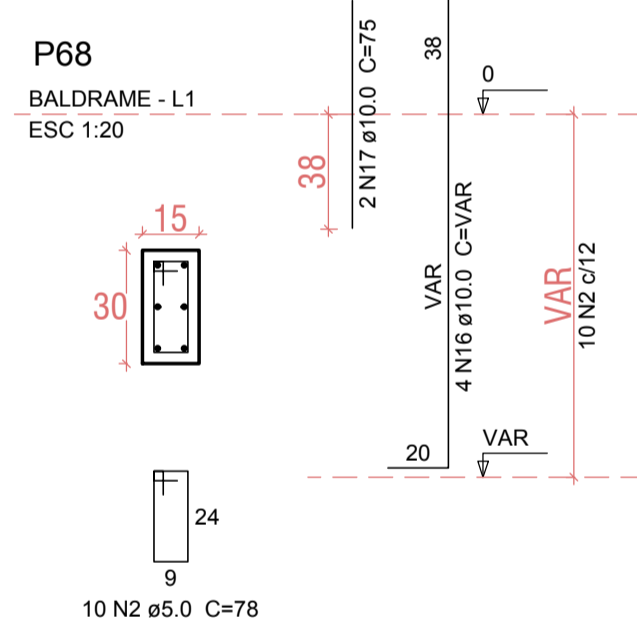
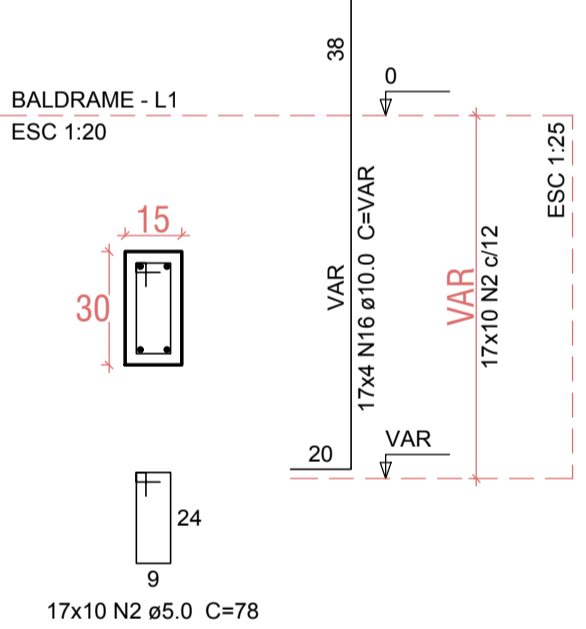

Resumo do aço

AÇO	DIAM (mm)	C.TOTAL (m)	PESO + 10% (kg)
CA50	6.3	1122.3	302.1
	8.0	263.8	114.5
	10.0	486.3	329.8
CA60	5.0	524.2	88.9
PESO TOTAL (kg)			
CA50		746.3	
CA60		88.9	

Volume de concreto (C-25) = 16.59 m³
 Área de forma = 120.64 m²

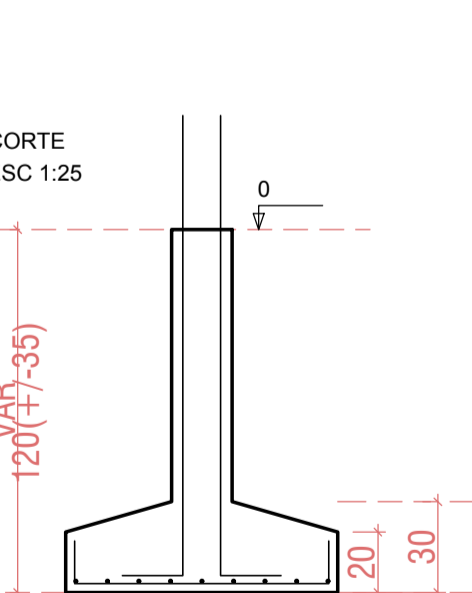
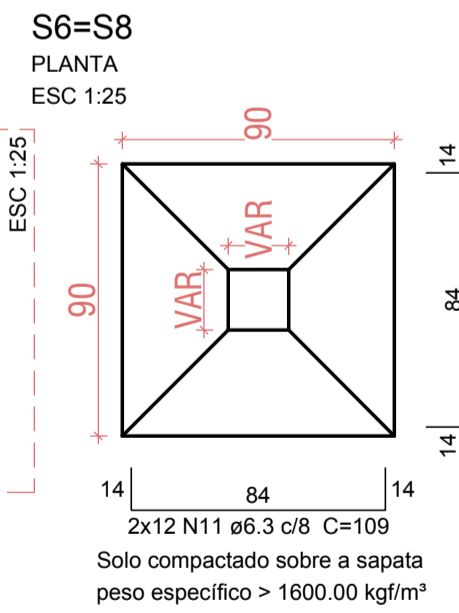
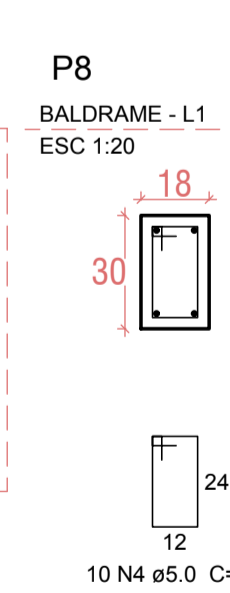
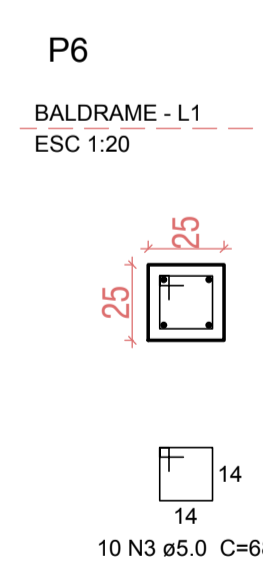
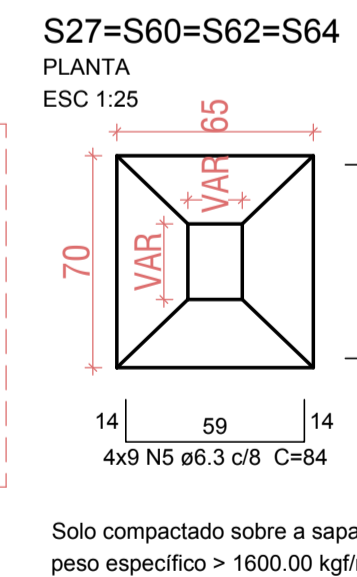
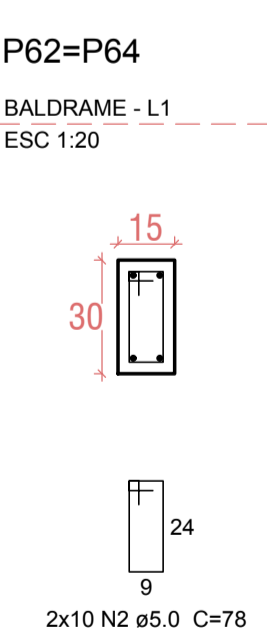
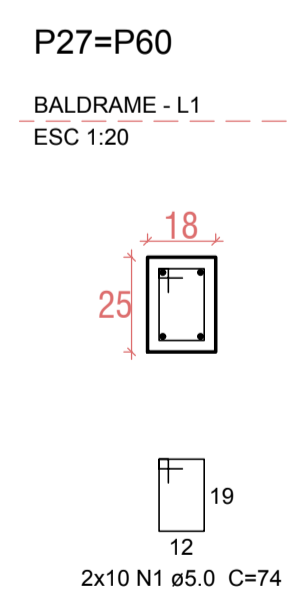

PREFEITURA MUNICIPAL DE PARANAGUÁ

TÍTULO	PROJETO ESTRUTURAL				
OBJETO	U.B.S. PRAIA DE ENCANTADAS - ILHA DO MEL				
CONTÉUDO	SAPATAS				
ELABORADO POR	RUY JOSÉ RIBEIRO	PROPRIETÁRIO			
ELABORADO EM	18/05/20	MUNICÍPIO DE PARANAGUÁ			
DATA/VERSÃO	JULHO/2017	ESCALA	INDICADA	REVISÃO	RJR
		ÁREA COBERTA			405,95 m²
					02/11